

# WOODWORKERS NEWS



Northeastern  
Woodworkers  
Association

February 2023, Vol. 32, Number 2

## Tom McLaughlin to Present All Day Demonstration and Class

*Save the date: Saturday, February 11*

This year the Fiske Memorial Lecture will be a very special event. Carl Stoner, our Program V.P., has arranged for Tom McLaughlin to spend a day in our Learning Center teaching the techniques used to make fine furniture. Even if you are not presently planning such a project, this is an opportunity to improve your woodworking skills and get inspired to bring your woodworking to the next level.

Tom has chosen to focus his demonstrations around the creation of a Contemporary Bowfront Sofa Table, as the accompanying photos illustrate. His sessions will cover (in this order):

- Design considerations
- Joinery processes
- Shaping and veneering the sides
- Methods for making a Bowfront Drawer
- Veneering, edge banding, and Inlay ideas for the top.
- And time permitting, finishing options

This event is offered free of charge but space in our Learning Center is limited. Please register early; we need a head count to plan effectively. (We will stream the event on Zoom for members who cannot attend in person.) Join us in the NWA's Herm Finkbeiner Learning Center, located at 97 Railroad Avenue in Albany on Saturday, February 11 from 9 AM to 5 PM. We will be catering lunch to provide an opportunity for attendees to network and maximize their experience. You may register [Here](#).

About our presenter:

After a 30+ year career as a Master Craftsman, Tom McLaughlin shifted his focus to teaching in 2016. He provides online courses and in-shop classes at his shop in Canterbury, N.H. Be sure to check out Shop



*Our presenter, Tom McLaughlin*



*The Bowfront Table*

Night Live, Thursdays at 8 PM each week. It's free - catch the link [Here](#). Can't watch it live? There are over 175 episodes archived at the *Epic Woodworking YouTube channel*, check them out anytime!



*The Bowfront Table*

## New Showcase Online Promotions

As Showcase enters our fourth decade (yes, it's now been 31 successful years), we are joining the modern era and adding Internet marketing to supplement our tried-and-true promotion of our unique event. The banner below is designed to highlight some of the special reasons, families and wood lovers will want to attend Showcase.

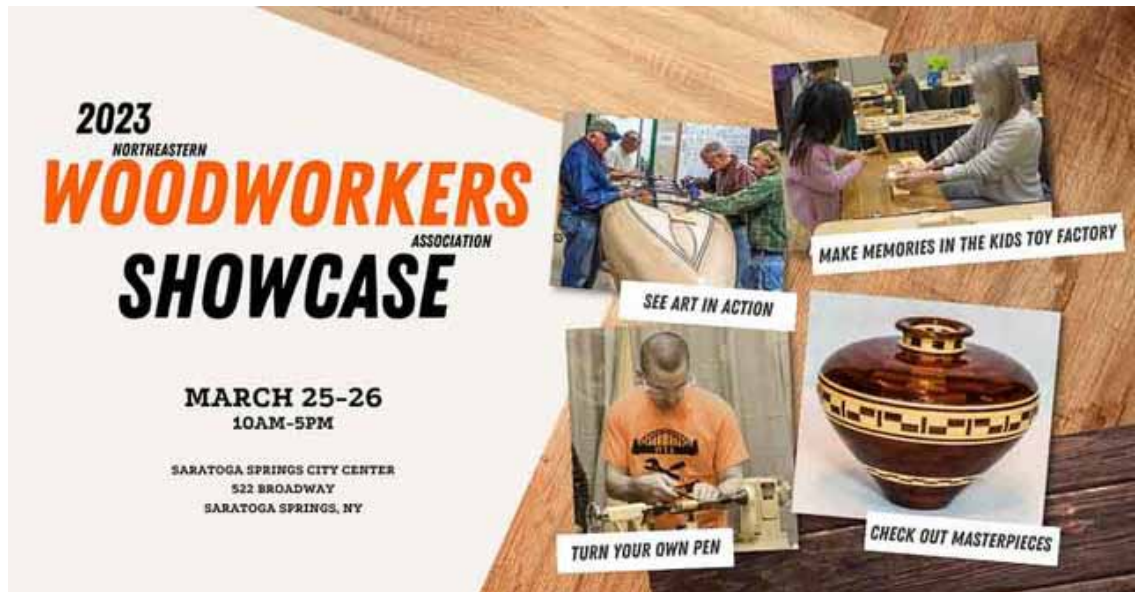

You will find it on our social media posts, our Eventbrite online ticket sales, and other places that our creative members think to place it. Two weeks before the show we plan to send out many thousands of "Facebook boosts" to remind the general community that the weekend of March 25 and 26 holds a special opportunity for them.

A special thank you to Alyssa Gatto for this art.

## NWA Member Featured Exhibit

*By Steve Schoenberg*

We have seen Ken Miller demonstrate joinery at Showcase and give us helpful insights at our monthly meetings. And now we can all enjoy the creative side of Ken and his talented wife, Brunhilde. The Valley Artisans Market is featuring our own members during a special exhibit January 20 through February 14. There will be an artist reception Saturday, January 21st at 3:00 – 5:00 PM. For more details, please follow the link below.

<https://www.valleyartisansmarket.com/events/event/b-k-miller/>

# Showcase 2023 Gallery Update

By Dale Lombardo, Showcase Gallery Registration Co-Chair

Hello NWA Woodworkers!!!

For 2023, I want to keep in front of each of you how the Gallery Registration process is going. I am hoping this will remind and inspire you to help us fill the Gallery with items to show each other and our visitors the variety of what is possible with woodworking!

Per the graph below, we are off and running with 5 items registered as of today\*. Plotting the 2023 item count against the backdrop of 2018-19, 22 showcase registrations shows we are off to a good and normal start! \*\* The horizontal axis is the “countdown to Showcase Friday” measured in days. The vertical axis is the cumulative item registration\*\*\* up to that day. We all have a history of doing/registering things at the last minute, well, in the last week or two anyway. We are so human.

I know some of you like to see the details of the item counts, so I’m adding the total table below. It is the tally by category of items for this year up to the date shown, and the total tally of items that were in the gallery for each Showcase year shown.

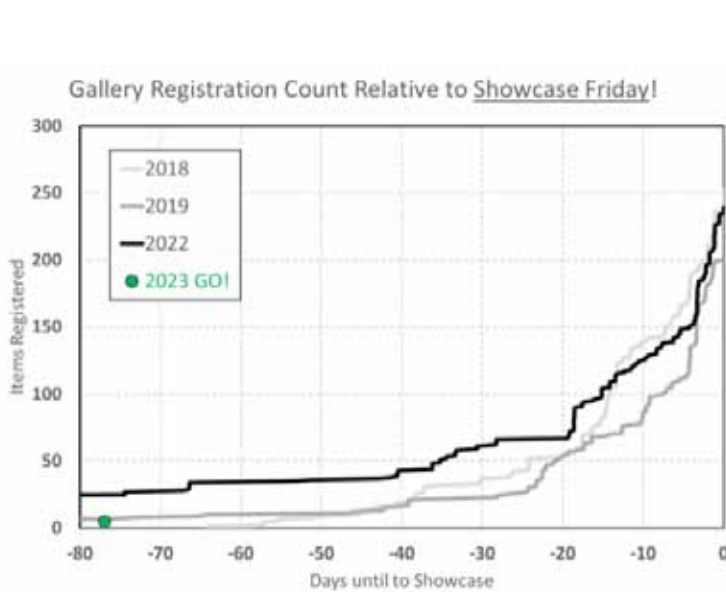

		Totals			
		252	211	239	5
Category		2018	2019	2022	1/7/2023
ACCESSORY1	Desktop Accessories & Clocks	32	10	21	-
ACCESSORY2	Small Boxes	22	19	12	-
ACCESSORY3	Kitchen Utility	-	8	16	-
ADIRONDACK	ADK style furniture and accessories	14	13	5	-
ALTMATL	Any subject.	16	11	3	1
BOATS	Functional boats	2	2	3	-
CARVING1	Chip or Relief Carving	13	12	9	-
CARVING2	3D representations of living things	3	28	20	1
CARVING3	3D functional items	18	****	9	-
CARVING4	3D ornamental or abstract Items	12		26	-
CHALLENGE	Coasters!! Protect fine furniture!	1	2	26	1
CNC-LASER	Made by CNC and/or Laser	3	6	5	-
FURNITURE1	Tables and beds	32	28	16	-
FURNITURE2	Bookcases, cabinets, chests, ...	9	9	12	1
FURNITURE3	Chairs and benches	9	12	7	-
INTARSIA	Items showing skill in intarsia	10	7	7	-
JEWELRY	Wooden jewelry of all forms	4	2	-	-
MARQUETRY	Items in marquetry	-	-	2	-
PYROGRAPHY	Items in pyrography	3	4	5	-
SCALED	Scaled models	-	-	4	-
SCROLL	Items by scroll saw	9	10	2	-
SHOPEQUIP	Wood tools, fixtures, and jigs	9	7	6	-
TOYS	Toy and play things for children	12	12	5	1
WOODMUSIC1	Stringed musical instruments	15	7	12	-
WOODMUSIC2	Non-stringed musical instruments	4	2	6	-

The online form is up and running on the [About Showcase](#) page. [Click Here](#) to use the online form.

If you want to see the details on the categories for 2023, [Click Here](#).

The paper form is still available and can be downloaded, printed, filled out, and mailed in. [Click Here](#) or there’s also a few forms and category sheets in the shop on the bulletin board!

I AM SINCERELY LOOKING FORWARD TO SEEING ALL YOU AND YOUR ITEMS IN MARCH! DON’T HESITATE TO REACH OUT IF YOU HAVE ANY PROBLEMS WITH THE REGISTRATION PROCESS!

Dale Lombardo

Showcase Co-Chair for Judging

ShowExhibit@gmail.com

\* This data snapshot is from Saturday January 7 at 9am. 😊

\*\* 2022 had an unfair advantage since a 20+ items from 2020 were registered and showed up in 2022.

\*\*\* I also subtracted all the items that did NOT show up to Showcase. It happens, but they don’t count.

\*\*\*\* In 2019, Carving categories were condensed, but restored/updated in 2020 and beyond.



## OFFICERS

**President** - Irv Stephens

**Vice President** - Carl Stoner

**Secretary** - Susan McDermott

**Treasurer** - Paul Ruud  
nwatreasurer2@gmail.com

**Executive Secretary** - Charlie Goddard



## NWA BOARD MEMBERS

Pete Chast

Charlie Goddard

Dale Lombardo

Susan McDermott

Paul Ruud

Steve Schoenberg

Irv Stephens

Chris Stolicky

Carl Stoner



## Mid-Hudson Chapter

Bill Sterling, President  
wster1156@aol.com

## Sacandaga Chapter

Vacant



## CHAIR/CONTACT PERSONS

### Auction and Hospitality

Lee Hilt

nwaauction1@gmail.com

### Education

Chair pro tem - Dave Mobley

nwaeducation1@gmail.com

Registrar - Jon Bennett

Members - Jim Lefebvre, Rich Glover

### Fiske Fund

Chairperson - Woody Bowler

fiskefund@gmail.com

Treasurer - Juliana Shei

fftreasurer@yahoo.com

Members - Jon Bennett, Dick Flanders,

Bill Sterling

### Historian

Wayne Distin

### Library

Susan Hill

### Membership

Alan Hayes

NWAMembers1@gmail.com

### Newsletter Editors

Steve Schoenberg, Irv Stephens

nwanewsletter1@gmail.com

### Publicity

John Olenik

jolenik@nycap.rr.com

### Showcase Chair

Wally Carpenter

nwa.showcase.chair@gmail.com

# A Look at an Entry Level Laser Engraver

By Wally Cook

Laser engravers are increasingly accessible to the woodworker. One cost effective model is the **Jinsoku LE-1620**. Here's an out of the box look at this product.

**Jinsoku LE-1620:** Ordered from SainSmart, the Jinsoku or Genmitsu-branded product is a German and Chinese collaboration. It features a 5.5 watt laser and an x-y frame that can accept an 8x10" engraving. Some accessories are available, including a rotary roller. The cost of the hardware, software-key and roller was under \$350 at the time I purchased the unit. Typically, the base unit without the roller accessory can be found between \$240-\$300.

Software is key to running the engraver. I used Laser GRBL and have found it to be a pretty easy interface to use, once a few quirks are understood. Error codes are not intuitive, but there is a help function. Basic issues that an entry level user may experience are:

1. Using the HOME setting to anchor the graphic to be engraved. The anchor default is the lower left corner of the graphic. The HOME setting will allow greater control in placing an engraving on desired spot – it lets the user move the home setting closer to the center of the graphic. Test fire the laser to show where the engraver will place the logical center of the engraving on the target area.
2. Printing Reversal: While the screen display will show a .jpg of your text and graphic in the alignment you desire, the engraving function may reverse the alignment initially. There are keys for cropping and rotating the image to ensure correct direction of the engraving. It's wise to test the graphic first on a piece of cardboard, before final engraving. There is a helpful grid that can be downloaded and printed to use on the base of the engraving bed to line up the piece to be engraved.
3. The Jinsoku has the ability to allow you to manually place the laser in the field and provides a FRAMING function. I've found that the framing function often does not accurately describe the limits of the engraved space. As a consequence, the engraving may stop in mid-run, if it believes that the engraver is asked to go beyond it's x-y limit. The user can abort the engraving in progress and restart, by choosing reset and unlock.

The functionality of the Jinsoku is pretty flexible, but a real benefit is the ability to create toggles. The toggle creates a button for a function, so you don't have to enter individual code settings.

The core functions provided by the engraver are dependent on power, engraving speed, and number of lines per mm. Power

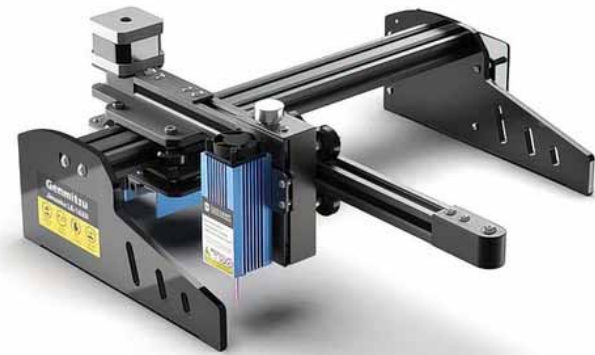

*Jinsoku le 1620 laser engraver*

## WOODWORKERS NEWS

is published by the Northeastern Woodworkers Association for its members. The Association's aim is to provide a common meeting ground for lovers of woodworking who want to know more about wood and the techniques for forming it. The newsletter is published monthly. The newsletter is available online at [www.woodworker.org](http://www.woodworker.org)



Your next issue of  
**Woodworkers News**  
will be published  
in early March

Copy deadline: February 10  
Steve Schoenberg, Irv Stephens  
Editors  
Nwanewsletter1@gmail.com  
Elizabeth Keays Graphic Artist  
Designer



### WEBSITE

[www.woodworker.org](http://www.woodworker.org)

Webmaster: Andy Moss  
[nwawebmasterhelp@gmail.com](mailto:nwawebmasterhelp@gmail.com)



**NORTHEASTERN  
WOODWORKERS ASSOCIATION**  
P.O. BOX 246  
Rexford, New York 12148



and speed serve to determine the depth and burn of the laser. Various materials – even species of different woods – will react differently to the combination of these variables. Jinsoku provides a materials database with guidance for settings for engraving and cutting. One of the benefits of a laser engraver is the ability to cut through veneers for marquetry applications.

There is also a selection of engraving approaches which lets the user change scalability and style:

1. Line-to-line is a faithful representation of the graphic
2. Dithering provides a sampling – a pixelation – of the graphic. This selection reduces the size of the file for quicker execution
3. Vectorize outlines the graphic, primarily for cutting pieces
4. Centerline simplifies the graphic by reducing it to central lines
5. Pass Through accepts the settings of the original .jpg with no editing allowed

Likes and Dislikes: The Jinsoku is price accessible and portable. I like the out of the box ease of use. Setting the focal point is really simple – a set-up jig is provided. Clearly, practice is important to master the plethora of options which it presents. As a novice, I have a lot to learn.

However, there are some aspects that should be easier. I wanted to engrave pens both in a line and also around the circumference; I assumed that the roller would suffice for circumference etching. Just to back up a little, the roller hooks into the y-axis controller and a stepper motor controls the speed of rotation, while the engraver works along the x-axis. The issue is that the roller cannot accept cylinders less than 3/4" in diameter. Creating a carrier for a pen blank has been a challenge. The diameter of the outer carrier moves at a different speed than the reduced pen cylinder. If the blank is even slightly off centerline, circles become saggy ovals, engraved off-center. The Help Center techs were not able to assist with the speed settings for small objects. The roller is definitely meant for engraving mugs.

Secondly, lining up the center point of the engraving file is tricky – more an approximation. The software could be more helpful in assigning an exact center, which then can be lined up with a grid placed on the table surface.



*The Jinsoku can be used for a variety of applications, including marquetry*



*Scalability is very good – expanding or minimizing the graphic is a function of the size function*



*Centering within your boundaries can be tricky*

# President's Column: Showcase Runs on Volunteers

*By Irv Stephens*

Hello, Woodworkers - Whenever I look at the calendar now, I start thinking about NWA's 30th Showcase coming up in March, and I'm reminded of the first two lines of a refrain from an old polka song:

Enjoy Yourself! Enjoy Yourself! It's later than you think.

Enjoy yourself! Enjoy yourself while you're still in the pink.

Next, I start thinking about how Showcase runs entirely on 200+ members volunteering; and volunteering at Showcase, as many NWA members have come to know, is a great way to stay in the pink!

This is especially true for new members. NWA's Showcase is the one event that brings all us together at one time for a jam-packed weekend. By volunteering for a few hours on a weekend in March members get to meet lots of other woodworkers, make new friends and see the full scope of NWA. Plus you get a free day's admission to Showcase.

With all that in mind, don't be surprised if SIG leaders soon contact you about volunteering at Showcase. An online link to volunteer also will soon be appearing on NWA's website.

There is another way also the you can help, and that by exhibiting one or more pieces that you've created. You can find out how to register those pieces now from our Showcase webpage:

<https://woodworker.org/about-showcase/>.

- Stay safe and volunteer, Irv Stephens

# Ornament Made by Milan Fiske Available for Purchase

*By Dave Mobley*

A holiday ornament made by NWA founding member Milan Fiske is being offered for sale by the daughter of Darwin Rossman. Rossman was a close friend of Milan's, and some NWA members will remember his demonstrations of micro-marquetry at several Showcases in the 1990s. The ornament, approximately 3.5" x 3.75", is made of a variety of woods (see photos). Milan constructed the ornament so the word "PAX" reads correctly from both sides, even though the ornament is thin enough that light from a flashlight shines through the lighter colored wood (see Side 2 photo). If you are interested in purchasing this ornament, please contact Dave Mobley at [dmobley@nycap.rr.com](mailto:dmobley@nycap.rr.com) for more information.



*A Christmas tree design with the word PAX, made from a variety of woods.*

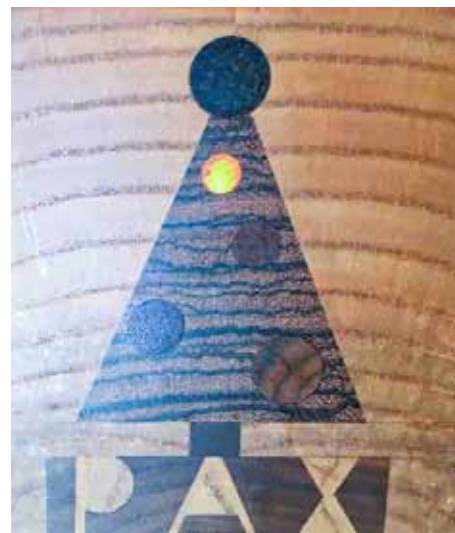

*Light shines through parts of the ornament, but "PAX" reads correctly on the reverse side as well.*



# NWA Booth at Shaker Heritage Sale – A Big Hit!

By *Linda Reiss, Store Sale Chair*

For the third year in a row, the NWA space at the Shaker Heritage Society Holiday Sale was a must-visit booth. We sold a majority of our inventory (232 items) for total sales of just over \$2,100. The NWA share of that amount was about \$1,500. Cutting boards, toast tongs, toy cars and trucks, Christmas items, small boxes and cedar scent hangers were some of the popular items.

In addition to supporting our educational mission, the SHS Holiday Sale give us excellent exposure to the many hundreds of visitors to the two-month event as evidenced both by the sales and the number of NWA cards and brochures we distributed.

Sincere thanks go out to each and every NWA member who contributed to the sale; particular kudos to the NWA Crafters who really stepped up with a range of useful items and holiday décor.

We are now gearing up for the Showcase store in March where we have a lot more space to show off the artistry and skill of our talented members to a large audience of woodworking enthusiasts. As we did for the SHS Holiday Sale, we are welcoming donations to the Showcase store which can be dropped off in the conference room at the Learning Center at 97 Railroad Avenue.



*A large variety of fine NWA woodworking at the Shaker Heritage sale*

## Call for Showcase Store Items

Showcase visitors walk through the gallery of amazing woodworking creations wishing they could take a piece of fine woodworking home with them. Well, they can – with your help! Please share your creations with our guests with contributions to the NWA store. Our guests love turned items (bottle stoppers, bowls, decorative pieces), toys, home décor, ...

Items for sale can be dropped off in the conference room of the NWA Learning Center at 97 Railroad Avenue or pick up can be arranged. Need more information? Email: [nwashop97gmail.com](mailto:nwashop97gmail.com)



*Sue Roberts and the display of items for sale at the Mid-Hudson "Celebration of Woodworking" in October*

# Machine Knowledgeable Class Survey Results Will Shape Future Classes

By Ray Puffer and Dave Mobley (Education Programs)

In November we sent out a survey to club members, asking for feedback on our Machine Knowledgeable (MK) training classes. We are very pleased with the response to that survey by nearly 80 club members. We asked for the level of experience respondents have on the various machines in the shop; which machines are the highest priority for MK level classes; preferred class meeting times; and comments on our program.

We received several comments, which will help us as we move forward with our program. Among those comments are:

- One member asked if the MK classes will be offered at the Kingston facility. Curricular materials will be made available to the Mid-Hudson leadership team, so they may make the classes more available to Mid-Hudson members.
- A few members suggested additional topics for consideration for future classes. This information will be considered by the NWA Education Committee in their class planning.

- Several members stated that they have already taken one or more MK level classes, and found them to be very informative, and well presented. They plan to continue taking these courses.

- A request was made that sufficient advance notice of scheduled classes be provided to allow personal schedules to be adjusted.

As a result of this survey we now have a database of members, the classes they prioritize, and the times/days they prefer for those classes. We will schedule and prioritize classes for those who rated the classes as either high or moderate level of interest, and contact those members for registration. We plan to increase the frequency of classes to respond to this high demand. The critical constraint is the availability of Machine Qualified instructors.

Our thanks to all members who have completed the survey, those who have taken MK level classes already, and those who have expressed their interest in future classes.



Ernie Balch made this CNC carved Comfort Bird bowl from a piece of Tiger Maple firewood. It's finished with mineral oil and it measures 12" W x 5.5" H x 2" thick.



# Mid-Hudson Chapter Elections

Ron Roberts reports that the Mid-Hudson Chapter recently elected the following slate of officers for two year terms:

William Sterling - President  
Richard Cerruto - Vice President  
Patsy Boisvert - Treasurer  
Ron Moore - Secretary

## Classifieds

*By Lee Hilt*

### Joe Perry Tool Sale

Former NWA member, Joe Perry, of Altamont is moving to Florida the end of February 2023. He needs to sell his entire shop. The below is a list of Joe's woodworking tools and equipment. We urge anyone to visit Joe's shop to inspect his array of fine tools. Time is of the essence. Please contact Joe for details. 518-603-0161

- Hegner Multimax 18" scroll saw with attached magnifier light dozens of various blades include.
- Trademaster "Helping Hand" outfeed board support.
- Ryobi oscillating sander with various sized spindles and sandpaper roll sizes.
- Jet upright large vacuum.
- Delta Hollow chisel mortise mounted on steel tool storage cabinet.
- Porter Cable plunge router with original carrying case.
- Delta 10" Contractor's Saw with Jet vacuum attached, Delta Unifence, including Rockler hold down grippers. Saw is mounted on foot action roller base. MUST SEE.
- Porter Cable plate joiner with lifetime supply of biscuits.
- Irwin Quick Grip clamps: Five at 40", Two at 12", Six at 6".
- Eight 24" screw handle type clamps.
- Two heavy cast steel type clamps...those with orange colored parts, 40".
- Two large wooden clamps used for joining large boards.
- Various size steel pipe clamps.
- Tru Grip clamp'n tool guides...two 50" one 24"
- Porter Cable pancake air compressor.
- Bosch large heavy duty vibrating drill...used for drilling concrete or stone.
- Porter Cable hand circular saw with case and Forest blade.
- Hitachi 8 1/2" sliding compound miter saw, again with Forest blade.
- Veritas wheel marking gauge.
- Veritas Inca Jig with instructions and plans for various functions.
- Porter Cable random orbital sander...Porter Cable vibrating sander 4".
- Black and Decker electric speed plane.
- Forstner bit set up to 1-5/8" also have one measure 2-3/8" ideal for running plastic pipe through.
- Various stainless steel rulers and stainless steel T-square.



## SPECIAL INTEREST GROUPS

### **SPECIAL INTEREST GROUPS (SIGs):** Please note meetings will commence at our new location at 97 Railroad Avenue.

**Adirondack Woodturners Association (AWA)** - The AWA is active throughout the year. **General** Meetings and Bowl Turning are held the first Wednesday of the month (except in January and July when it is the second Wednesday), at the NWA Learning Center located at 97 Railroad Avenue, Colonie, NY from 5:30 PM to 8:45 PM. **Contact:** Maxwell Ferris at maxwellferris@yahoo.com

**Spindle and Pen Turners** - Meets Mondays 5:30 PM - 8:45 PM. Contact: Pam Bucci at 518-429-6440 or woolglass2@gmail.com Wednesday "Learn and Turn" sessions occur on all other Wednesdays at the NWA Learning Center. These sessions run 5:30 PM to 8:45 PM. www.adirondackwoodturners.com **Contact:** Kevin Ramsey Cell 518-769-9665 or kmrammer@yahoo.com

**Kaatskill Woodturners** - KWA SIG no longer meets the second Saturday of the month. KWA plans a January meeting to establish a schedule for 2022 and to hold elections for officers. Contact: Wally Cook at wally.cook@gmail.com

**NWA Crafters** - Meet Tuesdays and Saturdays 9:00 AM to noon. They provide public service woodworking for various charitable organizations, including the Double H Hole in the Woods camp for children and the GE Toy Modifications Group, and the Make A Wish Foundation. Sharing information, fellowship, and relating experiences are a major part of these sessions. **Contact:** Wayne Distin at 518-674-4171 or wdistin@nycap.rr.com for more information.

**The NWA Wood Carvers SIG** - Meet Thursdays 5:00-8:30 PM all year at the NWA Learning Center located at 97 Railroad Avenue, Colonie, NY. The goal is to promote the art of wood carving and to have a good time doing it. The only prerequisite is a desire to carve while making new friends. Wood, tools, and patterns are available. **Contact:** Diane Balch at 518-885-9899 or signs@balchsigns.com

**Hand Tool SIG** - Meets on the 1st and 3rd Tuesday of each month at 7:00-9:00 PM in the Herm Finkbeiner Education Center at 97 Railroad Avenue, Colonie, NY. **Contact:** Dave Parkis at 518-429-6581 for further details: dparkis@nycap.rr.com

**Scrollers SIG** - Meets every Monday and Wednesday 6 to 8:30 PM. **Contact:** Steve VanDerZee stevedz@msn.com

### **CHAPTERS**

**NWA Mid-Hudson** - Presently The chapter meets on Zoom and at in-person meetings on the first Thursday of the month at 7:30 PM except the month of July. Meetings are at the Hudson River Maritime Museum located at 50 Rondout Landing, Kingston NY 12401. **Contact:** midhudsonwoodworkers.org Bill Sterling, President - 845-532-3754 wster1156@aol.com